

**optimum**

energy products Ltd.  
Toll Free: 1.877.766.5412  
info@myflukestore.com

Order this online ▶

MyFlukeStore.com

**FLUKE**®

**Scopes built tough  
to keep up with you.**

ScopeMeter® now takes you into  
CAT IV environments.



**New**

ScopeMeter® 190 Series II

# See more. Fix more.

ScopeMeter® portable oscilloscopes take you into territory standard bench scopes can't go: where it's harsh, hazardous and dirty—without sacrificing any capabilities.

The Fluke 190 Series II ScopeMeter® oscilloscopes, with electrically isolated channels, are safety rated for industrial applications. These scopes combine rugged portability with the high performance of bench oscilloscopes to take you from troubleshooting microelectronics all the way into power electronic applications—and beyond.

Choose from two or four channel models with a wide range of bandwidth options. Fast sampling rates up to 2.5 GS/s, 400 ps resolution and deep memory of 10,000 samples per channel allow high-accuracy capture and display of waveform details, noise, and other disturbances.

Perform timing or amplitude related measurements on three phases or three-axis control systems, or simply compare and contrast multiple test points in a circuit under test. Features like TrendPlot™, ScopeRecord™, and Connect-and-View™ help you quickly diagnose industrial machinery, automation and process controls, and power electronics to minimize repair costs and downtime. These features make the oscilloscopes easy to use especially when diagnosing the most difficult problems like complex waveforms, intermittent events and signal fluctuations or drift.

New Li-ion battery technology keeps your scope on the job, all day.

**Fluke 190 Series II ScopeMeter test tools are available with two or four channels, 60 MHz to 200 MHz. Choose the model that's right for your environment and budget.**



**optimum**  
energy products ltd.

Toll Free: 1.877.766.5412  
info@myflukestore.com

Order this online 

MyFlukeStore.com

# Built to withstand harsh environments with the highest safety ratings

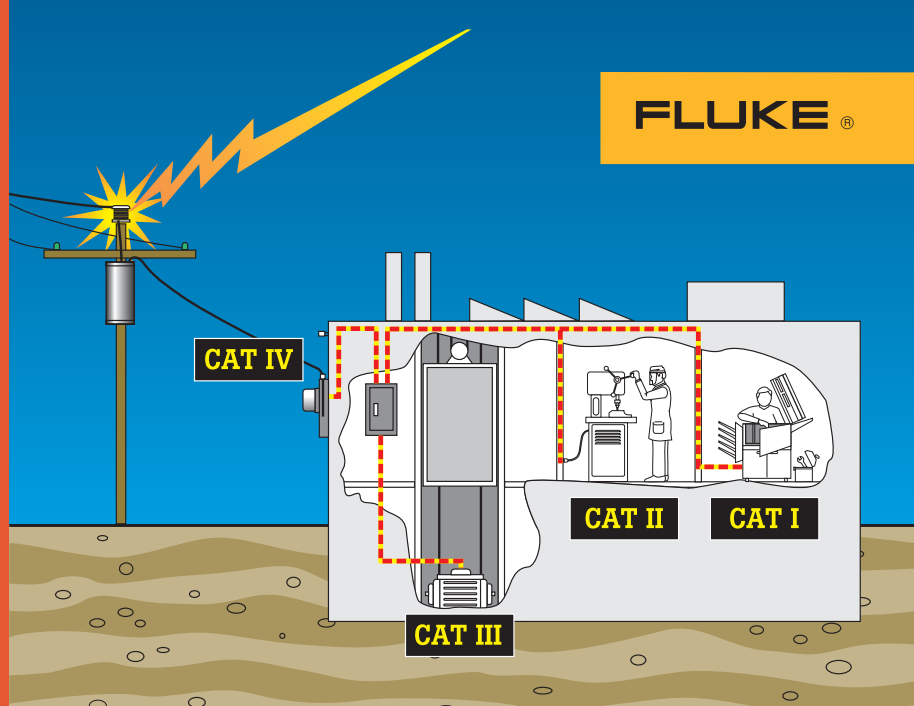

### Rated all the way to CAT IV

ScopeMeter test tools are rugged solutions built for industrial troubleshooting. The new Fluke 190 Series II are double-insulated floating oscilloscopes safety rated for measurements in CAT III 1000 V/CAT IV 600 V environments.

### Measure from mV to kV safely

Independent isolated inputs allow you to make measurements in mixed circuits having different ground references reducing the risk of accidental short circuits.

Conventional bench oscilloscopes without special differential probes and isolation transformers can only reference measurements to line power earth ground.

With standard probes that cover a wide application range from mV to kV, you're ready for anything from microelectronics to heavy-duty higher voltage electrical applications.

### IP-51 rated for harsh environments

Rugged and shock-proof, ScopeMeter portable oscilloscopes are built for dirty, hazardous environments. With its sealed case, it can endure dust, drips, humidity and airborne pollutants. Every time you reach for ScopeMeter you can be confident it will work reliably wherever your work takes you.

| Overvoltage category | In brief   | Examples   |
|----------------------|--|--|
| CAT IV               | Three-phase at utility connection, any outdoor conductors            | <ul style="list-style-type: none"> <li>Refers to the "origin of installation," that is, where low-voltage connection is made to utility power</li> <li>Electricity meters, primary overcurrent protection equipment</li> <li>Outside and service entrance, service drop from pole to building, run between meter and panel</li> <li>Overhead line to detached building, underground line to well pump</li> </ul> |
| CAT III              | Three-phase distribution, including single-phase commercial lighting | <ul style="list-style-type: none"> <li>Equipment in fixed installations, such as switchgear and polyphase motors</li> <li>Bus and feeder in industrial plants</li> <li>Feeders and short branch circuits, distribution panel devices</li> <li>Lighting systems in larger buildings</li> <li>Appliance outlets with short connections to service entrance</li> </ul>  |
| CAT II               | Single-phase receptacle connected loads                              | <ul style="list-style-type: none"> <li>Appliance, portable tools, and other household and similar loads</li> <li>Outlet and long branch circuits                             <ul style="list-style-type: none"> <li>Outlets at more than 10 meters (30 feet) from CAT III source</li> <li>Outlets at more than 20 meters (60 feet) from CAT IV source</li> </ul> </li> </ul>                                     |
| CAT I                | Electronic   | <ul style="list-style-type: none"> <li>Protected electronic equipment</li> <li>Equipment connected to (source) circuits in which measures are taken to limit transient overvoltages to an appropriately low level</li> <li>Any high-voltage, low-energy source derived from a high-winding resistance transformer, such as the high-voltage section of a copier</li> </ul>                                       |

Table 1. Overvoltage installation categories. IEC 61010 applies to low-voltage (< 1000 V) test equipment.

**optimum**  
energy products ltd.  
Toll Free: 1.877.766.5412  
info@myflukestore.com

Order this online ▶

MyFlukeStore.com

# Multiply your diagnostic powers with the new Fluke 190 Series II Portable Oscilloscopes

## Introducing the scopes with CAT IV rating

The first CAT III 1000 V/CAT IV 600 V rated, two- and four-channel portable scopes on the market, the new Fluke 190 Series II brings an unprecedented combination of performance and ruggedness into the field.

## Take on new challenges in industrial machinery, automation and process controls, power conversion electronics

Analyze timing and amplitude relationships of multiple signals simultaneously, easily compare and contrast waveform traces spotting irregularities with ease.

- For three-phase power applications like industrial motors and drives, UPS and inverters for wind energy, solar, and diesel locomotive controls for transportation
- For three-axis testing when you need to measure input, output and control signals simultaneously

## The ultimate in portability

New high-performance batteries take advantage of Li-ion technology to keep you going strong for up to seven hours. With the easy-access battery door you can make battery swaps fast.

## USB connectivity makes it easy to capture and share waveforms

The new Fluke 190 Series II offers two USB ports, electrically isolated from measurement input circuits. Easily transfer data to a PC. Archive and share waveforms with OEMs, colleagues and support staff. Store waveforms, screen captures and instrument setups onto USB memory devices.



New



Learn more about ScopeMeter applications with the new Fluke 190 Series II.



**optimum**  
energy products ltd.

Toll Free: 1.877.766.5412  
info@myflukestore.com

Order this online

MyFlukeStore.com

# What could you do with four channels?

Take multiple measurements simultaneously to track down the root cause of your most complex troubleshooting challenges.

## Easily diagnose timing-related issues with multiple signals

- Real-time inspection of multiple related signals simultaneously
- Measure a combination of input and output signals and system safety interlocks and feedback loops

## Find problems in industrial systems including:

- Circuit voltage/current overloading
- Attenuation/input impedance mismatch
- Signal fluctuation/drift
- Conditioning circuits signal integrity
- Test point verification for critical signals
- Input/output/feedback timing issues
- Induced noise and disturbances
- Random shutdowns/reset

## Diagnose VSDs\* or power inverters and converters

- Harmonics, transients and loads in three-phase power input
- Troubleshoot dc to ac converters for faulty control circuits or output IGBT gate stages
- Cable interface—test PWM output for reflections and transients
- Vpwm measurement to measure the effective voltage on drive outputs

\*Variable Speed Drive

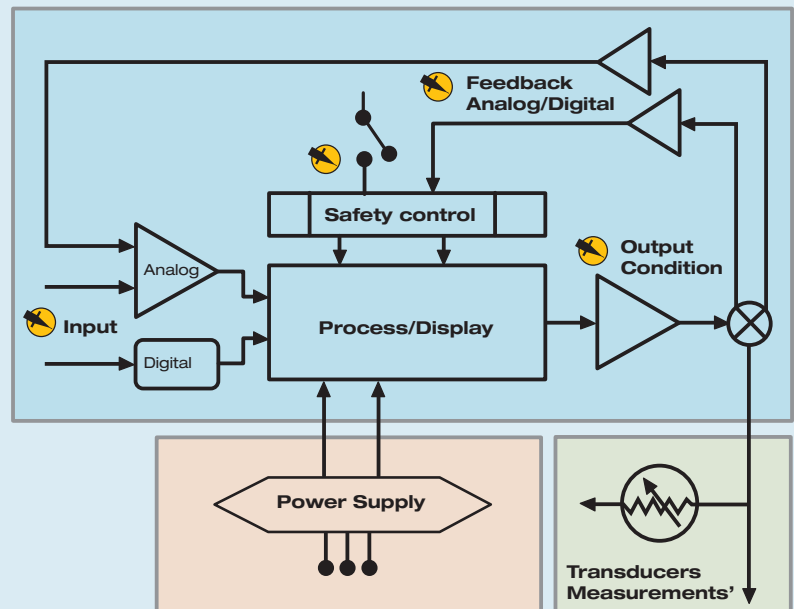

**For industrial electronics, four channels allow you to perform three-dimensional testing, measuring input, output and feedback signals simultaneously.**

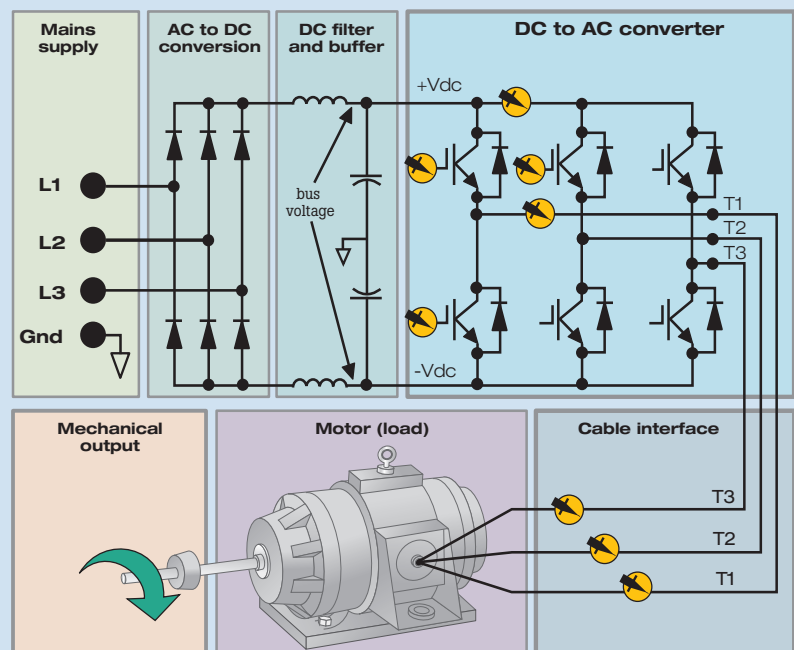

**In three-phase systems like variable speed drives, UPS or back-up generators, use four channels to diagnose power input, dc to ac converters, or cable interface problems.**

**optimum**  
energy products ltd.

Toll Free: 1.877.766.5412  
info@myflukestore.com

Order this online

MyFlukeStore.com

# Fluke ScopeMeter test tools work harder to make your job easier

See what's happening with fast real-time high resolution sampling. ScopeMeter offers a sample rate of up to 2.5 GS/s with up to 400 ps resolution.

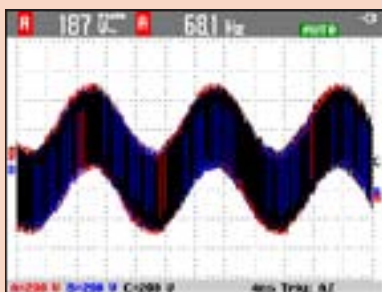

Connect-and-View™ captures even the most complex motor drive signals.



The built in multimeter provides convenient precision measurements.



Trend multiple measurements capturing signal intermittent events, signal drift or fluctuations.

## Connect-and-View™ triggering for an instant, stable display

If you've used other scopes, you know how tricky triggering can be. If settings are incorrect, results can be unstable or incorrect. Connect-and-View™ automatically sets up correct triggering by recognizing signal patterns. Without touching a button, you get a stable, reliable and repeatable display of virtually any signal including motor drive and control signals. It's especially fast and convenient when you're measuring a number of test points in rapid succession.



## Built-in digital multimeter

190 Series II models with isolated dual input scope and dedicated digital multimeter. Conveniently switch from waveform analysis to precise multimeter measurements using the built in 5000 count digital multimeter. Measurement functions include Vdc, Vac, Vac+dc, resistance, continuity and diode test. Measure current and temperature using suitable shunt, probe or adapter with wide range of scaling factors.

## ScopeRecord™ mode for high resolution waveform recording up to 48 hours

ScopeRecord™ memory stores up to 30,000 or more data points per channel, capturing fast intermittents and glitches as short as 8 ns. (Two sets of multiple-channel recordings can be stored for later analysis.)

- Records events like motion profiles and UPS, power supply or motor start-up cycles
- With the Stop on Trigger mode, the ScopeMeter automatically recognizes a power failure and stores the waveform data preceding it

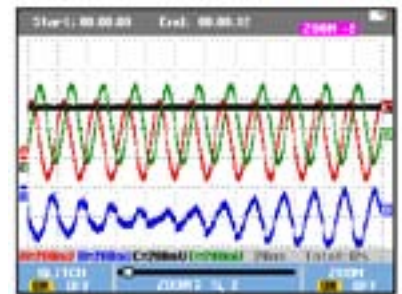

Capture high-resolution waveform details over extended period using ScopeRecord™ mode.

## TrendPlot™ paperless recorder—records up to 16 days to help you find intermittent faults

The toughest faults to find are those that happen once in a while. These intermittents can be caused by bad connections, dust, dirt, corrosion, or simply broken wiring or connectors. Line outages, sags or starting and stopping of a motor can also cause a machine to stop. You may not be around when it happens, but the Fluke ScopeMeter will.

- Plot minimum and maximum peak values and average over time up to 16 days
- Plot any combination of voltages, amps, temperature, frequency and phase for all four inputs, all with time and date stamp to pinpoint faults



**optimum**  
energy products ltd.  
Toll Free: 1.877.766.5412  
info@myflukestore.com

Order this online

MyFlukeStore.com



Conveniently store and transfer critical waveform data using isolated USB ports.

**optimum**  
energy products ltd.  
Toll Free: 1.877.766.5412  
info@myflukestore.com

Order this online

MyFlukeStore.com

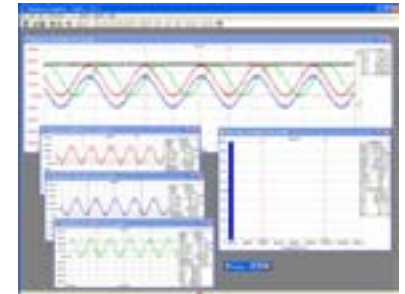

**Persistence, FFT, mathematics and pass/fail waveform envelope testing**



Pass/Fail testing of actual signal against a reference template.

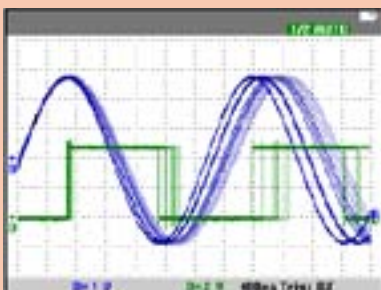

Digital Persistence mode gives analog scope-like display of complex and modulated signals.

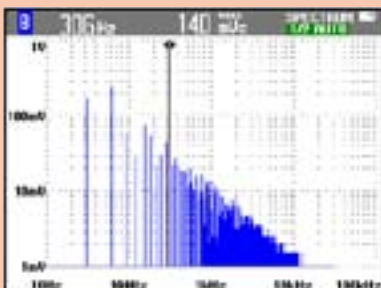

Frequency Spectrum shows an overview of frequencies contained in a signal.

**Look back in time with automatic capture and display of last 100 screens**

It's frustrating to see a one-time anomaly flash and miss it. Fluke ScopeMeter solves the problem by letting you look back in time with a touch of the replay button.

- In normal use, the instrument continuously memorizes the last 100 screens. As each new screen is acquired, the oldest is discarded.
- At any moment you can "freeze" the last 100 screens and scroll through picture-by-picture or replay as a "live" animation
- Use cursors for further analysis
- Advanced triggering lets you capture up to 100 specific events (Two sets of 100 captured screens with individual time stamps can be stored for later recall or downloaded to a PC or USB stick.)

**Cursors and automatic waveform measurements**

With 30 automatic measurements, cursors, and zoom, ScopeMeter will perform automatic power and Vrms measurements on specific portion of the waveform within a specified time span.

**Time Stamp**

Real-time clock allows you to find out when a specific event was recorded.

**FlukeView® ScopeMeter software for documenting, archiving and analysis**

Get more out of your ScopeMeter with FlukeView® ScopeMeter® SW90W Software for Windows.

- Documentation—transfer waveforms, screens and data to your PC for printing or importing data into a report
- Add text to ScopeMeter settings—give operators guidance when recalling settings
- Archive—create a library of waveforms for easy reference, waveform comparison, or pass/fail testing
- Analysis—use cursors, perform spectrum analysis or export data to another analysis program
- Connect to your PC with optically isolated USB port

## A broad family of ScopeMeter models

Choose the model that fits your applications and budget.

Fluke offers the broadest range of bandwidths in portable oscilloscopes—from 20 MHz to 200 MHz.



### ScopeMeter 190 Series II: Be prepared for anything in a CAT IV world with three-axis and three-phase testing.

- 190-XX4 model with four independent isolated inputs
- 190-XX2 models with two independent isolated scope inputs and DMM input
- Choose 60 MHz, 100 MHz or 200 MHz bandwidth
- Fast sample rate: up to 2.5 GS/s with up to 400 ps resolution
- Single shot, pulse width and video triggering
- Deep memory: 10,000 point per trace waveform capture
- CAT III 1000 V/CAT IV 600 V, safety rated
- Up to seven hours of operation with high-performance Li-ion batteries (four hours with 2 channel models)
- Battery door for conveniently swapping out batteries to extend usage time plus optional external charger
- Two isolated USB ports, for memory devices and PC connectivity
- Security slot to lock down instrument using standard Kensington® lock
- Plus all the standard features of ScopeMeter including TrendPlot™, Connect-and-View™ triggering and ScopeRecord™

**Coming soon!**

### Watch for the new ScopeMeter 190 Series II

500 MHz, 5 GS/s coming soon. Innovation and advancements in electronics continue to take significant leaps. See how the new 500 MHz ScopeMeter stays one step ahead of these advancements.



500 MHz, 5 GS/s unprecedented performance in a hand-held portable oscilloscope.

Visit [www.fluke.com/ScopeMeterSeriesII](http://www.fluke.com/ScopeMeterSeriesII) and be the first to learn how you can put a 500 MHz portable oscilloscope to work for you.

### ScopeMeter 120 Series: Three-in one simplicity for electrical or electromechanical troubleshooting.

- It's an oscilloscope, a multimeter and a paperless recorder in one affordable, easy-to-use instrument
- Dual input
- Up to seven hours of battery operation
- CAT III 600 V safety rated
- Automatic measurements
- Choice of 40 MHz or 20 MHz bandwidth
- Two 5,000 count true-rms digital multimeters
- Includes standard ScopeMeter features like Connect-and-View™ and TrendPlot™ recording
- Model 125 offers network bus health and power measurements for industrial systems testing





## Industry applications

|  | Industrial   |   | Industrial Electronics                                     |  | Electronic Field Service                |  |  |
|--|--|---|--|--|---|--|--|
| Technologies   | Electrical   | Electro-mechanical  | Process Controls   | Automation   | Medical Imaging                         | Avionics   | A/V & Security Systems   |
| Equipment  | Switch Gear, Interlocks, Motors, Pumps, Fans, Furnaces, Presses, Mixers, Refrigeration | Actuators, VFD Drives, Linear Motors, Pressure-Level-Flow-Position Sensors, Packaging Equipment | Transducers / Sensors, Loop Controllers, Calibrated Gauges | PLC's, Sensors, Transducers < Motion Controllers, Rotary Encoders, Scanners, Readers, Printers | XRay, MRI, Ultrasound Imaging equipment | Flight line Navigation Systems, Communication systems, Radars, On board aircraft control systems | Retail security devices, Surveillance and monitoring equipment, RFID |
| <b>120 Series: Electrical and Electromechanical Troubleshooting</b>  |  |   |  |  |   |  |  |
| 123  | •  |   |  |  |   |  |  |
| 124  |  | •   |  |  |   |  |  |
| <b>Industrial Network Bus Health Troubleshooting</b>   |  |   |  |  |   |  |  |
| 125  |  | •   | •  |  |   |  |  |
| <b>190 Series II: Industrial Electronics, Automation, Process Control Testing and Electronic Field Service</b> |  |   |  |  |   |  |  |
| 190-062  |  | •   |  |  |   |  |  |
| 190-102  |  |   | •  |  |   |  |  |
| 190-202  |  |   |  | •  | •                                       | •  | •  |
| 190-104  |  |   | •  |  |   |  |  |
| 190-204  |  |   |  | •  | •                                       | •  | •  |

Comprehensive selection guides will be available on the web and in the datasheet

## Selection guide

| Features                          | 120 Series |           |           | 190 Series II ScopeMeter   |                            |                            |               |               |
|-----------------------------------|------------|-----------|-----------|----------------------------|----------------------------|----------------------------|---------------|---------------|
|                                   | 123        | 124       | 125       | 190-062                    | 190-102                    | 190-202                    | 190-104       | 190-204       |
| Bandwidth (MHz)                   | 20         | 40        | 40        | 60                         | 100                        | 200                        | 100           | 200           |
| Scope inputs                      | 2          | 2         | 2         | 2                          | 2                          | 2                          | 4             | 4             |
| Dedicated DMM                     | 2          | 2         | 2         | 1                          | 1                          | 1                          | —             | —             |
| Dual Input Trendplot™             | •          | •         | •         | •                          | •                          | •                          | —             | —             |
| Four Input Trendplot™             | —          | —         | —         | —                          | —                          | —                          | •             | •             |
| ScopeRecord Mode                  | —          | —         | —         | •                          | •                          | •                          | •             | •             |
| Automatic Capture and Replay Mode | —          | —         | —         | •                          | •                          | •                          | •             | •             |
| Cursors                           | —          | •         | •         | •                          | •                          | •                          | •             | •             |
| Zoom                              | —          | —         | —         | •                          | •                          | •                          | •             | •             |
| Bus Health Test Mode              | —          | —         | •         | —                          | —                          | —                          | —             | —             |
| Advanced power measurements       |            |           | •         | •                          | •                          | •                          | •             | •             |
| EN61010-1 CAT IV Safety Rating    | —          | —         | —         | 600 V                      | 600 V                      | 600 V                      | 600 V         | 600 V         |
| EN61010-1 CAT III Safety Rating   | 600 V      | 600 V     | 600 V     | 1000 V                     | 1000 V                     | 1000 V                     | 1000 V        | 1000 V        |
| Battery                           | 7 hr NiMH  | 7 hr NiMH | 7 hr NiMH | 4 hour Li-ion (8 hour Opt) | 4 hour Li-ion (8 hour Opt) | 4 hour Li-ion (8 hour Opt) | 7 hour Li-ion | 7 hour Li-ion |
| Optical RS-232                    | •          | •         | •         | —                          | —                          | —                          | —             | —             |
| Isolated USB PC Interface         | Opt        | Opt       | Opt       | •                          | •                          | •                          | •             | •             |
| Isolated USB memory port          | —          | —         | —         | •                          | •                          | •                          | •             | •             |

# Ordering information

**optimum**  
energy products ltd.  
Toll Free: 1.877.766.5412  
info@myflukestore.com

Order this online ▶

MyFlukeStore.com



Fluke 190 Series II 4-channel instruments include a set of four probes, hanging strap, USB cable with mini-B connector, double capacity Li-ion battery BP291, battery charger/power adapter BC190, a FlukeView demo package and users manuals on CD-ROM. The /S-versions also include the C290 hard-shell carrying case and the FlukeView software package. The 2-channel models come with two probes plus a set of TL175 test leads and a single capacity battery BP290. SCC kit includes: Hard-shell carrying case, optically isolated USB interface cable, and FlukeView® for Windows® software.

## Models

|                 |   |
|-----------------|---|
| Fluke 190-204   | Color ScopeMeter, 200 MHz, 4 channels   |
| Fluke 190-204/S | Color ScopeMeter, 200 MHz, 4 channels, with SCC-290 kit included                    |
| Fluke 190-104   | Color ScopeMeter, 100 MHz, 4 channels   |
| Fluke 190-104/S | Color ScopeMeter, 100 MHz, 4 channels, with SCC-290 kit included                    |
| Fluke 190-202   | Color ScopeMeter, 200 MHz, 2 channels plus DMM/Ext.input                            |
| Fluke 190-202/S | Color ScopeMeter, 200 MHz, 2 channels plus DMM/Ext.input, with SCC-290 kit included |
| Fluke 190-102   | Color ScopeMeter, 100 MHz, 2 channels plus DMM/Ext.input                            |
| Fluke 190-102/S | Color ScopeMeter, 100 MHz, 2 channels plus DMM/Ext.input, with SCC-290 kit included |
| Fluke 190-062   | Color ScopeMeter, 60 MHz, 2 channels plus DMM/Ext.input                             |
| Fluke 190-062/S | Color ScopeMeter, 60 MHz, 2 channels plus DMM/Ext.input, with SCC-290 kit included  |
| Fluke 125       | Industrial ScopeMeter (40 MHz)  |
| Fluke 125/S     | Industrial ScopeMeter (40 MHz) + SCC120 kit   |
| Fluke 124       | Industrial ScopeMeter (40 MHz)  |
| Fluke 124/S     | Industrial ScopeMeter (40 MHz) + SCC120 kit   |
| Fluke 123       | Industrial ScopeMeter (20 MHz)  |
| Fluke 123/S     | Industrial ScopeMeter (20 MHz) + SCC120 kit   |

## Optional accessories

### Accessories for ScopeMeter 190 Series II

|          |   |
|----------|---|
| C290     | Hard shell protective carrying case for 190 Series II                   |
| HH290    | Hanging Hook for 190 Series II instruments                              |
| SCC290   | FlukeView Software (full version) and C290 Carrying Case kit            |
| VPS410-R | Voltage Probe set, 10:1, 300 MHz, one set red                           |
| VPS410-G | Voltage Probe set, 10:1, 300 MHz, one set grey                          |
| VPS410-B | Voltage Probe set, 10:1, 300 MHz, one set blue                          |
| VPS410-V | Voltage Probe set, 10:1, 300 MHz, one set green                         |
| VPS420-R | High voltage probe set 150 MHz, 100:1, CAT III 2000 V (1000 V to earth) |
| BC190    | Mains adapter/battery charger   |
| EBC290   | External battery charger for BP290 and BP291                            |
| TL175    | TwistGuard™ safety designed Test Leads set (1 red, 1 black)             |
| BP290    | Li-Ion battery pack, 2400 mAh   |
| BP291    | Li-Ion battery pack, 4800 mAh   |
| SW90W    | FlukeView® ScopeMeter Software for Windows®                             |

### Accessories for ScopeMeter 120 Series

|        |  |
|--------|--|
| SCC120 | FlukeView® Software + Cable + Case   |
| PM9080 | Optically Isolated RS-232 adapter/cable                                      |
| OC4USB | Optically Isolated USB interface cable                                       |
| DP120  | Differential Voltage Probe   |
| BHT190 | Bus Health Test break-out adapter for DB-9, RJ-45 and M12 connection systems |
| ITP120 | Optically Isolated External Trigger Input                                    |
| SW90W  | FlukeView® ScopeMeter Software for Windows®                                  |
| C120   | Hard Shell Carrying Case   |

**Fluke.** Keeping your world

#### Fluke Corporation

PO Box 9090, Everett, WA 98206 U.S.A.

#### Fluke Europe B.V.

PO Box 1186, 5602 BD  
Eindhoven, The Netherlands