

# USER'S MANUAL

ACD-6 Pro

ACD-6 TRMS Pro

Versatile Clamp-on  
Multimeter Series

## 1) SAFETY

This manual contains information and warnings that must be followed for operating the instrument safely and maintaining the instrument in a safe operating condition. If the instrument is used in a manner not specified by the manufacturer, the protection provided by the instrument may be impaired.

The meter meets the requirements for double insulation to IEC61010-2-032(1994), EN61010-2-032(1995), UL3111-2-032(1999):

Category III 600 Volts AC and DC.

### PER IEC61010 OVERVOLTAGE INSTALLATION CATEGORY

#### *OVERVOLTAGE CATEGORY II*

Equipment of OVERVOLTAGE CATEGORY II is energy-consuming equipment to be supplied from the fixed installation.

Note – Examples include household, office, and laboratory appliances.

#### *OVERVOLTAGE CATEGORY III*

Equipment of OVERVOLTAGE CATEGORY III is equipment in fixed installations.

Note – Examples include switches in the fixed installation and some equipment for industrial use with permanent connection to the fixed installation.

#### *OVERVOLTAGE CATEGORY IV*

Equipment of OVERVOLTAGE CATEGORY IV is for use at the origin of the installation. Note – Examples include electricity meters and primary over-current protection equipment.

### TERMS IN THIS MANUAL

- **WARNING** identifies conditions and actions that could result in serious injury or even death to the user.
- **CAUTION** identifies conditions and actions that could cause damage or malfunction in the instrument.

**WARNING**

To reduce the risk of fire or electric shock, do not expose this product to rain or moisture. The meter is intended only for indoor use.

To avoid electrical shock hazard, observe the proper safety precautions when working with voltages above 60 VDC or 30 VAC rms. These voltage levels pose a potential shock hazard to the user.







Inspect test leads, connectors, and probes for damaged insulation or exposed metal before using the instrument. If any defects are found, replace them immediately.

Do not touch test lead tips or the circuit being tested while power is applied to the circuit being measured. To avoid accidentally short circuit of bare (uninsulated) hazardous live conductors or busbars, switch them off before insertion and removal of the current clamp jaws. Contact with the conductor could result in electric shock. Keep your hands/fingers behind the hand/finger barriers that indicate the limits of safe access of the meter and the test leads during measurement.

**⚠ CAUTION:**

Disconnect the test leads from the test points before changing meter functions.

**INTERNATIONAL ELECTRICAL SYMBOLS**

	Caution ! Refer to the explanation in this Manual
	Caution ! Risk of electric shock
	Earth (Ground)
	Double Insulation or Reinforced insulation
	Fuse
	AC--Alternating Current
	DC--Direct Current

**2) CENELEC Directives**

The instruments conform to CENELEC Low-voltage directive 73/23/EEC and Electromagnetic compatibility directive 89/336/EEC

### 3) PRODUCT DESCRIPTION

This user's manual uses only representative model(s) for illustrations. Please refer specification details for function availability to each model.

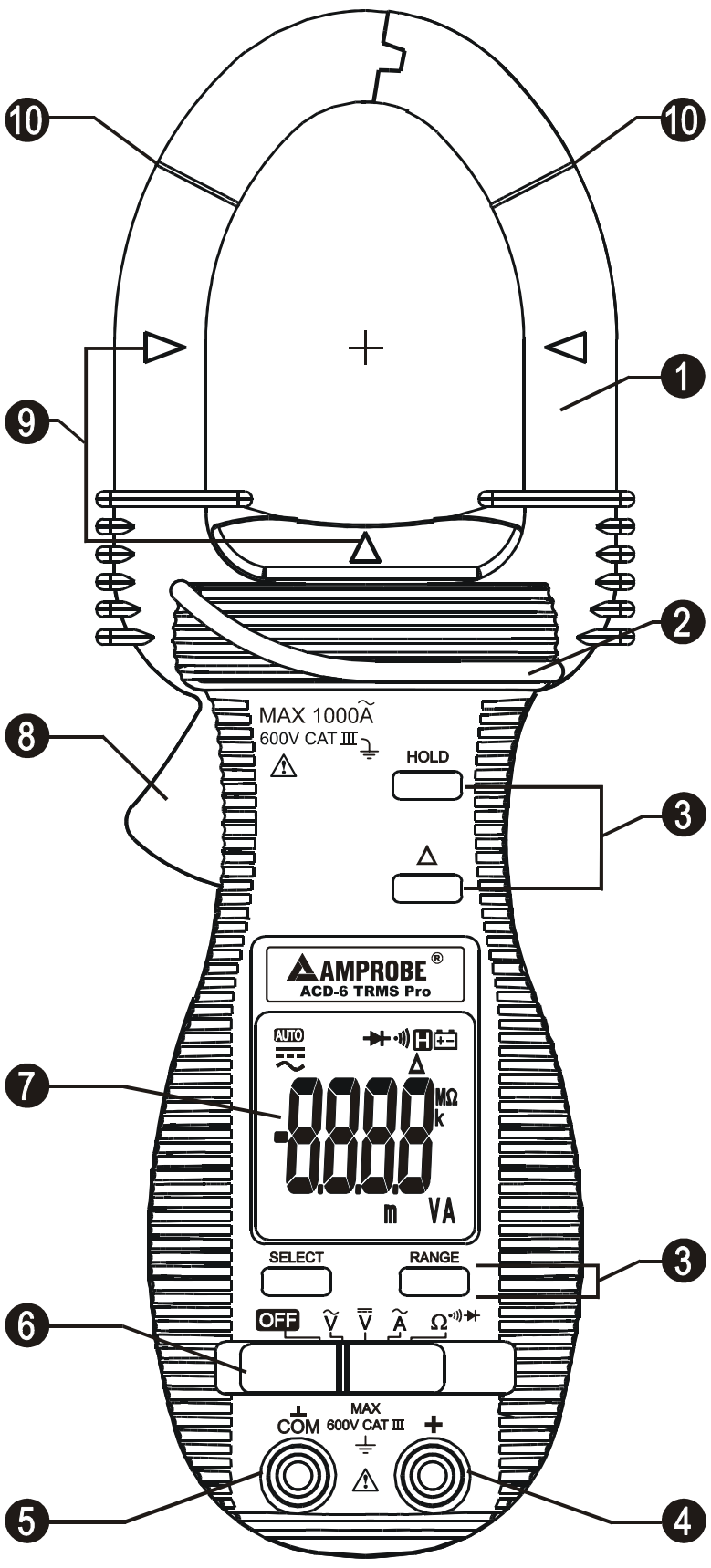

1) Transformer Clamp Jaw for AC current magnetic field pick up

2) Hand/Finger Barrier to indicate the limits of safe access of the meter during measurement

3) Push-buttons for special functions & features

4) Input Jack for all functions EXCEPT non-invasive ACA current function

5) Common (Ground reference) Input Jack for all functions EXCEPT non-invasive ACA current function

6) Slide-switch Selector to turn the power ON/OFF and Select a function

7) 3-3/4 digits 4000 counts LCD display

8) Jaw trigger for opening the transformer clamp jaw

9) Jaw center Indicators, at where best ACA accuracy is specified

10) Jaw marking lines for ACA position error indication

## 4) OPERATION

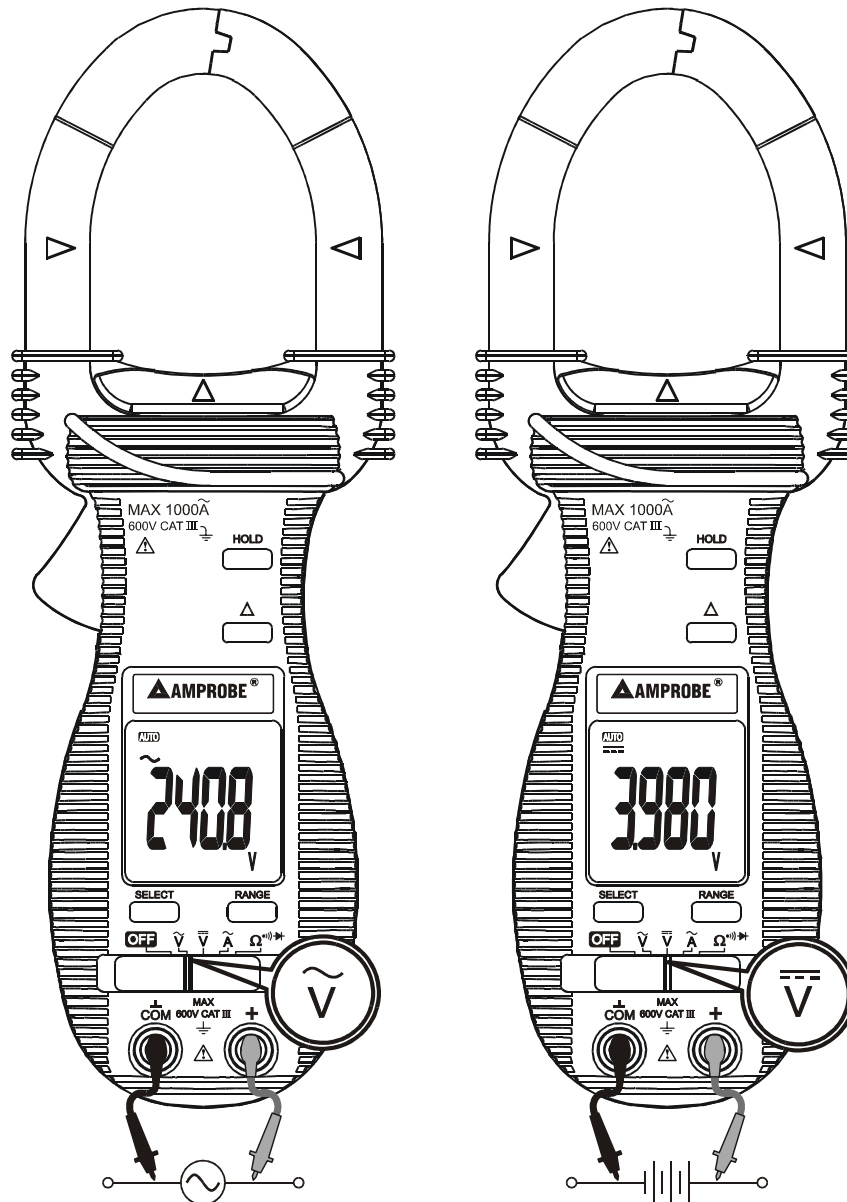

### DC Voltage and AC Voltage functions

Inputs are made through the test lead terminals.

Note: DC 400.0mV range is designed with 1000MΩ high input impedance for least current drain in measuring small signals, and can cope better with most commercially available voltage output transducers/adapters. The non-zero display reading is normal when the meter inputs are open circuit, which will not affect actual measurement accuracy. The meter will show a close to zero reading when the inputs are shorted. Open input is actually a floating condition, which is not a zero-volt-input condition.

Note: AC 400.0mV range selection is by RANGE button manually, and is specified from AC 40mV & up for ACD-6 Pro and from AC 60mV & up for True RMS model ACD-6 TRMS Pro.

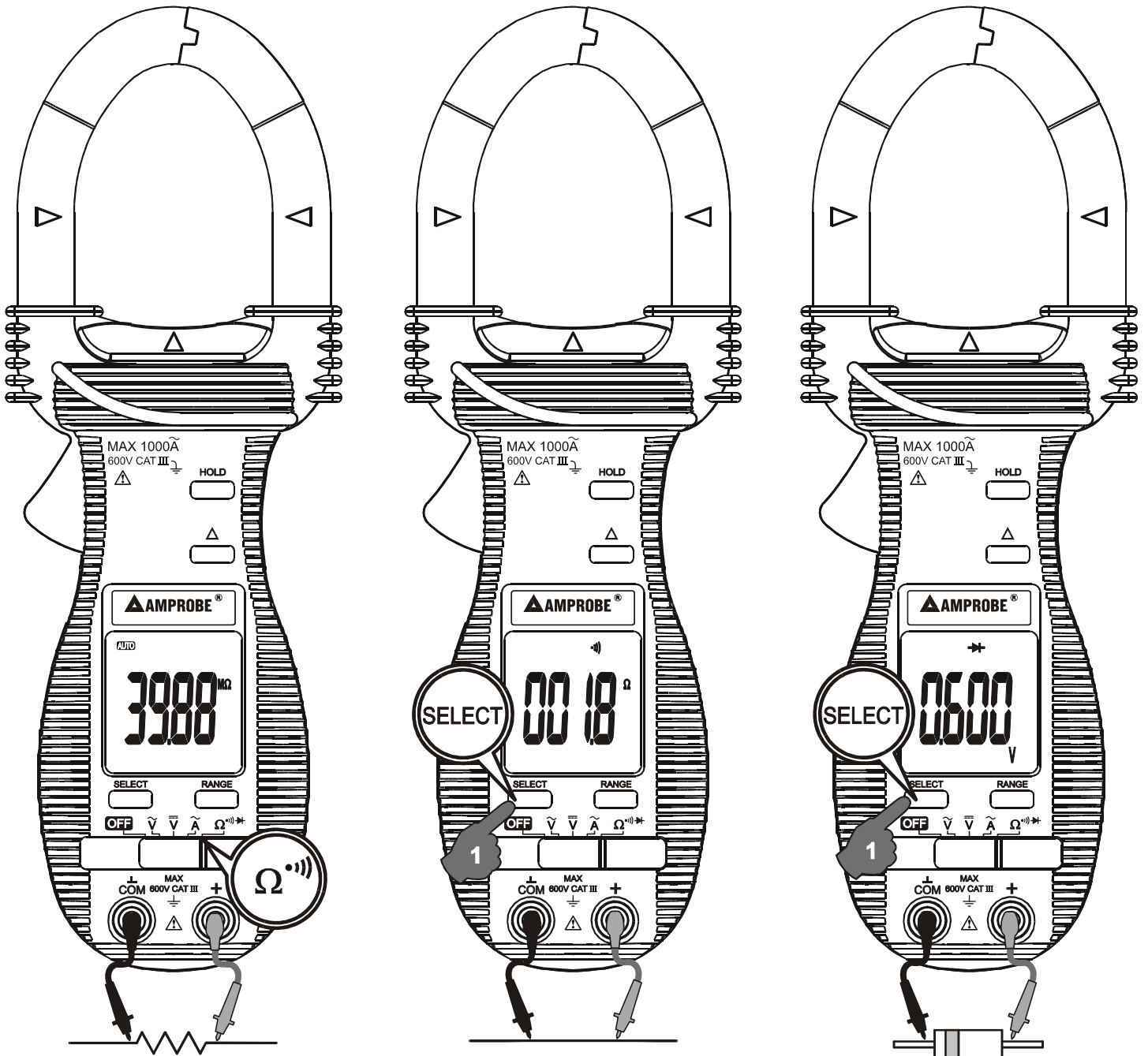

## CAUTION

Using Resistance, Continuity or Diode function in a live circuit will produce false results and may damage the instrument. In many cases the suspected component must be disconnected from the circuit to obtain an accurate measurement reading.

## Ω Resistance, and $\rightarrow$ ) Continuity functions

Inputs are made through the test lead terminals. Slide-switch on defaults at Ω. Press **SELECT** button momentarily to select  $\rightarrow$ ) Continuity function, which is convenient for checking wiring connections and operation of switches. A continuous beep tone indicates a complete circuit.

### → Diode test function

Inputs are made through the test leads terminals. Place slide-switch to  $\Omega$  position. Press **SELECT** button momentarily 2 times to select → Diode test function. Normal forward voltage drop (forward biased) for a good silicon diode is between 0.400V to 0.900V. A reading higher than that indicates a leaky diode (defective). A zero reading indicates a shorted diode (defective). An OL indicates an open diode (defective). Reverse the test leads connections (reverse biased) across the diode. The digital display shows OL if the diode is good. Any other readings indicate the diode is resistive or shorted (defective).

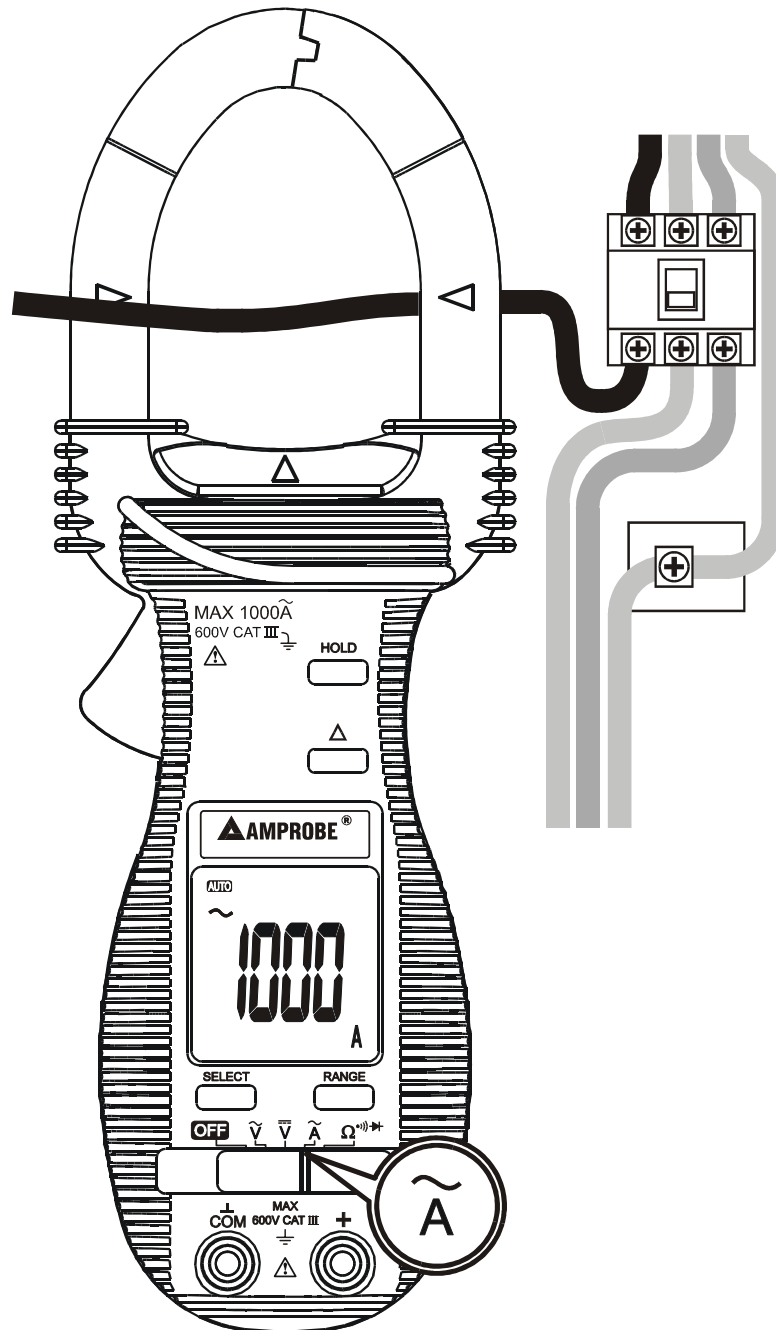

### ACA Current clamp-on function

Inputs are made through the clamp jaws for non-invasive ACA current measurements.

### CAUTION

Press the jaw trigger and clamp the jaws around only one single conductor of a circuit for load current measurement. Make sure the jaws are completely closed, otherwise this will introduce measurement errors. Enclosing more than one conductor of a circuit will result in differential current (like identifying leakage current) measurement.



Adjacent current-carrying devices such as transformers, motors and conductor wires will affect measurement accuracy. Keep the jaw's tip away from them as much as possible to minimize influence.



**HOLD** 

The hold feature freezes the display for later viewing. Press the **HOLD**  button momentarily to activate and to exit the hold feature.

**Relative zero**  mode

Relative zero  mode allows the user to offset the meter consecutive measurements with the displaying reading as the reference value. The display will now show readings relative to the stored reference value. That is, display = reading - stored value. Press the  button momentarily to activate and to exit relative zero mode.

**Manual or Auto-ranging**

Press the **RANGE** button momentarily to select manual-ranging mode, and the meter will remain in the range it was in, the LCD **AUTO** symbol turns off. Press the button momentarily again to step through the ranges. Press and hold the **RANGE** button for 1 second or more to resume auto-ranging mode.

**Auto Power Off (APO)**

When the meter is on, the Auto Power Off (APO) feature will switch the meter to sleep mode automatically after approximately 30 minutes of no slide-switch or push button operations to extend battery life. To wake up the meter from APO, press the buttons momentarily or set the slide-switch to the OFF position and then slide back on again. Always set the slide-switch to the OFF position manually when the meter is not in use.

## **5) MAINTENANCE**

### **WARNING**

To avoid electrical shock, disconnect the meter from any circuit, remove the test leads from the input jacks, and turn OFF the meter before opening the case. Do not operate with open case.

### **Trouble Shooting**

If the instrument fails to operate, check batteries and test leads etc., and replace as necessary. Double check operating procedure as described in this user's manual

If the instrument voltage-resistance input terminal is subjected to a high voltage transient (caused by lightning or switching surge to the system) by accident or abnormal conditions of operation, the series fusible resistors will be blown (become high impedance) just as standard fuses to protect the user and the instrument. Most measuring functions through this terminal will then be open circuit. The series fusible resistors and the spark gaps should then be replaced by qualified technician. Refer to the LIMITED WARRANTY section for obtaining warranty or repairing service.

### **Cleaning and Storage**

Periodically wipe the case with a damp cloth and mild detergent; do not use abrasives or solvents. If the meter is not to be used for periods of longer than 60 days, remove the batteries and store them separately

## Battery replacement

The meter uses one 3V coin battery (ANSI/NEDA-5004LC, IEC-CR2032).

To replace the battery, loosen the two screws from the case bottom and remove the bottom case. Slide the battery out the side of the holder (see example below) and replace with a new battery (observe polarity). Replace the bottom case. Re-fasten the screws.

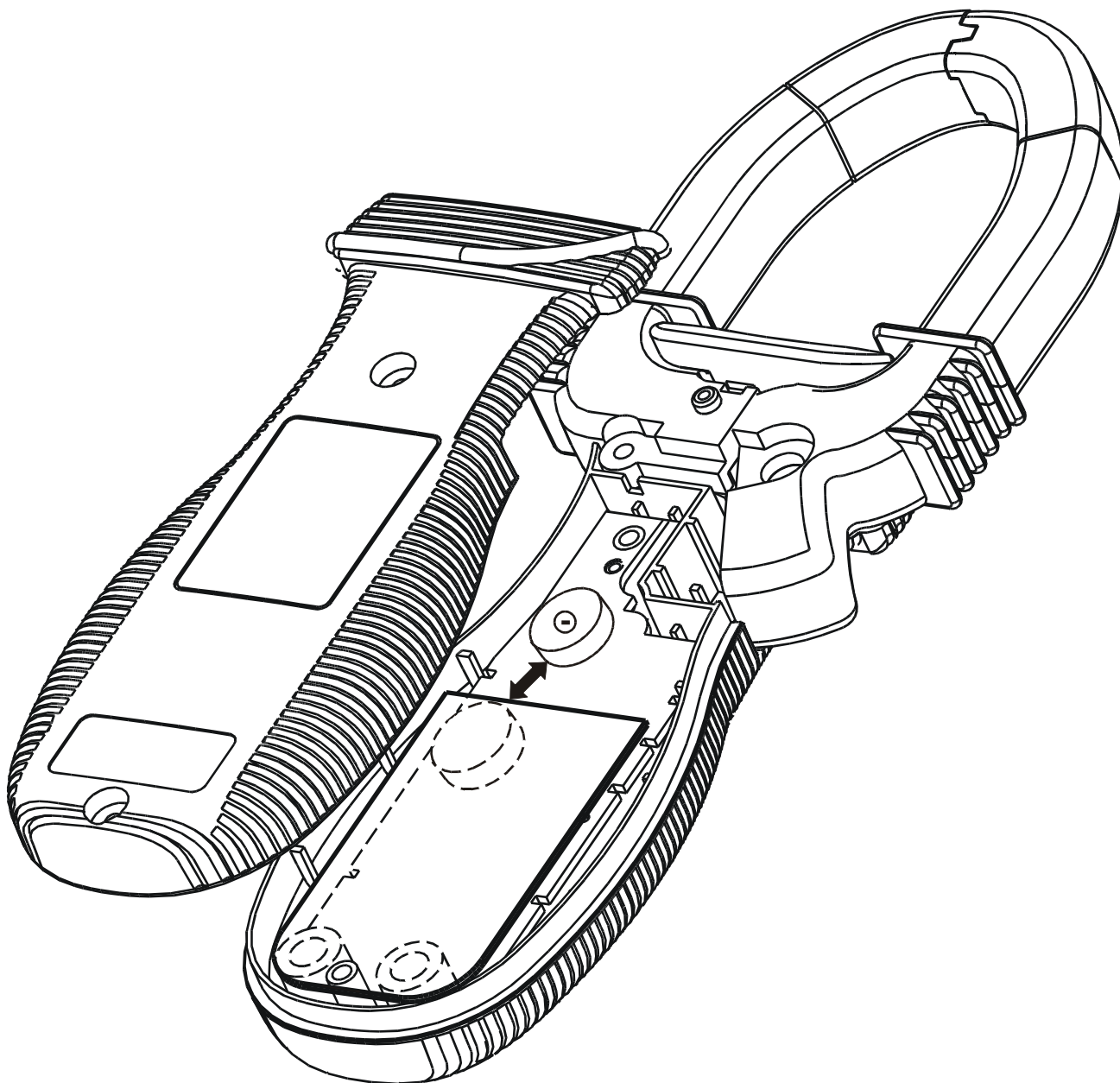

## 6) SPECIFICATIONS

### GENERAL SPECIFICATIONS

**Display** : 3-3/4 digits 4000 counts LCD display(s)

**Update Rate** : 3 per second nominal

**Polarity** : Automatic

**Low Battery** : Below approx. 2.4V

**Operating Temperature** : 32°F TO 104°F (0°C TO 40°C)

**Relative Humidity** : Maximum relative humidity 80% for temperature up to 31°C decreasing linearly to 50% relative humidity at 40°C

**Altitude** : Operate below 6,562ft (2000m)

**Storage Temperature** : -4°F to 140°F (-20°C to 60°C), < 80% R.H. (with battery removed)

**Temperature Coefficient** : nominal  $0.15 \times$  (specified accuracy)/°C @ 32°F - 64°F OR 82°F - 104°F (0°C -18°C or 28°C -40°C), or otherwise specified

**Sensing** : Average sensing for ACD-6 PRO; True RMS for ACD-6 TRMS PRO

**Safety** : Meets IEC61010-2-032(1994), EN61010-2-032(1995), UL3111-2-032(1999).  
Category III 600 Volts ac & dc.

**Transient protection** : 6.5kV (1.2/50μs surge) for all models

**Pollution degree** : 2

**E.M.C.** : Meets EN61326(1997, 1998/A1), EN61000-4-2(1995), and EN61000-4-3(1996)  
In an RF field of 3V/m:

Total Accuracy = Specified Accuracy + 45 digits

Performance above 3V/m is not specified

### Overload Protections :

ACA Clamp-on jaws : AC 1000A rms continuous

+ & COM terminals (all functions) : 600VDC/VAC rms

**Power Supply** : One 3V coin battery (ANSI/NEDA-5004LC, IEC-CR2032)

**Power Consumption** : ACD-6 Pro: 2.2 mA typical

ACD-6 TRMS Pro: 2.8mA typical

**APO Timing** : Idle for 30 minutes

**APO Consumption** : 40μA typical on all model functions except that 190μA typical on ACD-6 TRMS PRO voltage & current functions

**Dimension** : L224mm X W78mm X H40mm

**Weight** : 220 gm approx

**Jaw opening & Conductor diameter** : 45mm max

**Accessories** : Test leads (pair), batteries installed, user's manual, & soft carrying pouch

## ELECTRICAL SPECIFICATIONS

Accuracy is  $\pm$ (% reading digits + number of digits) or otherwise specified, at 73°F  $\pm$  9°F (23 °C  $\pm$ 5 °C) & less than 75% R.H.

True RMS Model ACD-6 TRMS PRO ACV & ACA clamp-on accuracies are specified from 5% to 100% of range or otherwise specified. Maximum Crest Factor are as specified below, and with frequency spectrums, besides fundamentals, fall within the meter specified AC bandwidth for non-sinusoidal waveforms.

### DC Voltage

RANGE	Accuracy
400.0 mV	1.0% + 3d
4.000V, 40.00V, 400.0V	1.7% + 3d
600V	2.0% + 4d

NMRR : >50dB @ 50/60Hz

CMRR : >120dB @ DC, 50/60Hz, Rs=1k $\Omega$

Input Impedance : 10M $\Omega$ , 30pF nominal  
(1000M $\Omega$  for 400.0mV range)

### Audible Continuity Tester

Open Circuit Voltage: 0.4VDC typical

Range: 400.0 $\Omega$ ; Accuracy: 1.5% + 6d

Audible threshold: between 10 $\Omega$  and 120 $\Omega$ .

### Ohms

RANGE	Accuracy
400.0 $\Omega$	1.5% + 6d
4.000k $\Omega$ , 40.00k $\Omega$ , 400.0k $\Omega$	1.0% + 4d
4.000M $\Omega$	1.5% + 4d
40.00M $\Omega$	2.5% + 4d

Open Circuit Voltage : 0.4VDC typical

### AC Voltage

RANGE	Accuracy
<b>50Hz -- 500Hz</b>	
400.0mV <sup>1)</sup>	4.0% + 5d
<b>50Hz -- 60Hz</b>	
4.000V, 40.00V, 400.0V	2.0% + 5d
<b>60Hz -- 500Hz</b>	
4.000V, 40.00V, 400.0V	2.5% + 5d
<b>50Hz -- 500Hz</b>	
600V	3.0% + 5d

CMRR : >60dB @ DC to 60Hz, Rs=1k $\Omega$

Input Impedance : 10M $\Omega$ , 30pF nominal

True RMS model ACD-6 TRMS PRO Crest  
Factor:

< 2.5 : 1 at full scale & < 5.0 : 1 at half  
scale

<sup>1)</sup>Selection by RANGE button manually, and  
is specified from AC 40mV (AC 60mV  
for True RMS model ACD-6 TRMS PRO)  
and up

### Diode Tester

Open Circuit Voltage	Test Current (Typical)
< 1.6 VDC	0.4mA

**ACA Current (Clamp-on)**

<b>RANGE</b>	<b>Accuracy</b> <sup>1) 2) 3)</sup>
<b>50Hz / 60Hz</b>	
400.0A	1.5% + 5d
1000A	1.5% + 5d*

True RMS model ACD-6 TRMS PRO Crest  
Factor:

< 2.6 : 1 at full scale & < 5.2 : 1 at half  
scale

<sup>1)</sup>Add 8d to specified accuracy while reading  
is below 15% of range

<sup>2)</sup>Induced error from adjacent current-  
carrying conductor: < 0.06A/A

<sup>3)</sup>Specified accuracy is for measurements  
made at the jaw center. When the  
conductor is not positioned at the jaw  
center, position errors introduced are:

Add 1% to specified accuracy for  
measurements made WITHIN jaw  
marking lines (away from jaw opening)

Add 4% to specified accuracy for  
measurements made BEYOND jaw  
marking lines (toward jaws opening)

## LIMITED WARRANTY

Congratulations! Your new instrument has been quality crafted according to quality standards and contains quality components and workmanship. It has been inspected for proper operation of all of its functions and tested by qualified factory technicians according to the long-established standards of our company.

Your instrument has a limited warranty against defective materials and/or workmanship for one year from the date of purchase provided that, in the opinion of the factory, the instrument has not been tampered with or taken apart.

Should your instrument fail due to defective materials, and/or workmanship during this one-year period, a no charge repair or replacement will be made to the original purchaser. Please have your dated bill of sale, which must identify the instrument model number and serial number and call the number listed below:

AMPROBE / Repair Department • Miramar, FL 33025

Phone: 954-499-5400 • Toll Free: 800-327-5060 • Fax: 954-499-5418

Website: [www.Amprobe.com](http://www.Amprobe.com)

Please obtain an RMA number before returning product for repair.

Outside the U.S.A. the local representative will assist you. Above limited warranty covers repair and replacement of instrument only and no other obligation is stated or implied.



Miramar, FL 33025 • Tel: 954-499-5400 • Fax: 954-499-5418 • [www.Amprobe.com](http://www.Amprobe.com)

P/N: 7M1C-0561-0001  
PRINTED IN TAIWAN